

# PIPESCAN™ HD

Mapping the Unseen.

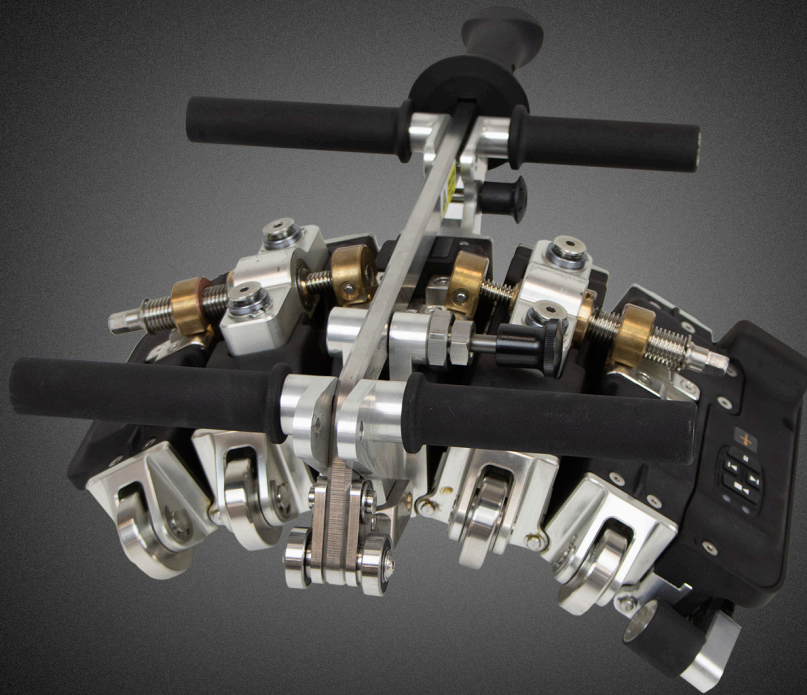



© Eddyfi UK Ltd

Clos Llyn Cwm, Swansea Enterprise Park, Swansea,

SA6 8QY, Wales, UK.

Pipescan HD™ User Manual Version 2

The text, figures and programs have been worked out with the utmost care. However, we cannot accept either legal responsibility or any liability for any incorrect statements which may remain, and their consequences. The following documentation is protected by copyright. All rights reserved.

Eddyfi reserves the right to continue developing the system and software without documenting each individual case. Eddyfi holds no responsibility for any damage or destruction caused when following instructions within this manual.

This manual is part of the original documentation supplied with the Pipescan HD™ system.

December 2021

# Table of Contents

<b>1. General Precautions and Conventions</b> .....	<b>2</b>
1.1 GENERAL PRECAUTIONS .....	2
1.2 SAFETY PRECAUTIONS .....	2
1.3 CONVENTIONS .....	4
1.4 DAILY PRE-SCAN CHECKS .....	5
1.5 ACRONYMS .....	7
<b>2. Introducing the Pipescan HD Family</b> .....	<b>9</b>
2.1 MFL TECHNIQUE .....	9
2.2 SPECIFICATIONS .....	10
2.3 FEATURES.....	11
2.3.1 Pipescan HD .....	11
2.3.2 Encoder - ENC-PS-HD.....	14
2.3.3 Cable PS-HD-CBL-R/S05 and PS-HD-CBL-E05 .....	15
<b>3. Acquisition Unit – Ectane2, Reddy or Swift-M</b> .....	<b>16</b>
3.1 ECTANE2 .....	16
3.2 REDDY AND SWIFT-M.....	17
<b>4. Software: Magnifi, Magnifi GO and Swift-M GO.....</b>	<b>19</b>
4.1 LAYOUT.....	19
<b>5. Getting Started</b> .....	<b>22</b>
5.1 SET UP YOUR PIPESCAN HD SYSTEM .....	22
5.2 DEPLOYMENT & REMOVAL .....	23
5.2.1 Deployment.....	24
5.2.2 Removal .....	26
5.3 CONNECT TO YOUR INSTRUMENT .....	27
5.4 CREATE OR LOAD YOUR SETUP .....	28

5.4.1 Create a new setup.....	28
5.4.2 Load existing setup file – Magnifi and Magnifi GO users only .....	31
<b>6. Alarm Threshold Adjustment.....</b>	<b>32</b>
6.1 THRESHOLD ADJUSTMENT USING A REFERENCE SAMPLE .....	32
6.2 THRESHOLD ADJUSTMENT BASED ON BACKGROUND NOISE .....	33
<b>7. Color Palette .....</b>	<b>34</b>
<b>8. Scan zone definition.....</b>	<b>35</b>
<b>9. Acquisition .....</b>	<b>38</b>
9.1 PERFORMING AN ACQUISITION WITH SWIFT-M GO.....	38
9.2 PERFORMING AN ACQUISITION WITH MAGNIFI OR MAGNIFI GO .....	39
9.2.1 Data Management .....	39
9.2.2 Acquisition .....	40
<b>10. Analysis and reporting.....</b>	<b>42</b>
10.1 MARKING AS YOU GO .....	42
10.2 MARKING AT THE END OF EACH SCAN .....	42
10.3 GENERATE A REPORT (AND MARK AT THE END OF THE INSPECTION IF NEEDED) .....	43
<b>11. Storage &amp; Transportation .....</b>	<b>45</b>
<b>12. Recommended Calibration / Reference Pipe Samples .....</b>	<b>46</b>
12.1 GENERAL RECOMMENDATION .....	46
12.2 SPECIFIC CORROSION TYPES .....	46
<b>13. Maintenance .....</b>	<b>48</b>
13.1 MAGNETIC BRIDGE MAINTENANCE .....	48
13.2 WHEEL REPLACEMENT – 127XFLAT .....	48



Chapter 1

# Precautions and conventions

# 1. General Precautions and Conventions

## 1.1 General Precautions

The following safety precautions must be observed at all times when using the Pipescan HD system. Make sure that you review them **before** turning on the system.

- Keep this document in a safe place for future reference.
- Carefully follow the installation and operation procedures detailed herein.
- Observe all warnings, notes and instructions as marked on the packaging, the scanner, and detailed in the user manual.
- Pipescan HD system should only be used by qualified personnel.
- When transporting Pipescan HD, it is your responsibility to follow all safety precautions as dictated by the relevant local governing bodies.
- The equipment must not be used for purposes other than those intended. Eddyfi assumes no responsibility for any damage resulting from such improper usage.
- If you use the system in a manner that deviates from the one specified by Eddyfi, the protection provided on the equipment may be rendered null and void.
- Do not use substitute parts or perform unauthorized modifications to the system.
- Service instructions, when applicable, are intended for trained service personnel only.
- Ensure by regular checks that the working site, equipment and environments are kept in a clean and clearly arranged state.
- Rules and regulations regarding the prevention of accidents that apply to the working site should be observed.
- The Pipescan HD is protected from water spray in all directions. However, submersion or exposure to pressurised jets may result in system damage.
- Dry system as well as practicable before returning to transit case for storage to keep system in best condition.
- If the system does not operate normally, contact Eddyfi for assistance.
- Do not leave the Pipescan HD system unattended on pipe or surface when not in use.

## 1.2 Safety Precautions

Observe the following safety precautions rigorously when using Pipescan HD.

### WARNING

- **Pinch Hazards & Powerful Magnets**

The Pipescan HD system utilises powerful magnets and as such presents an inherent finger trap risk. **Care must always be taken** when handling and using the Pipescan HD system.



- **Removal / Deployment / Carrying / Shipping**

Due to the powerful magnets involved, the breaker handle used to deploy and remove the Pipescan HD head from the surface can exhibit a strong downward force and presents a finger trap. The user must be in control of the breaker handle at all times.



**Only use** the black breaker handle and the removal / deployment / carry handles when attempting to remove, deploy and carry the Pipescan HD. **Do not use the umbilical cable or any other part as a lifting point.** If moving the Pipescan HD over long distances, use the dedicated transport case. **Care must always be taken** when handling and using the Pipescan HD system. If supplied, the locking pin **must** be used to ensure the breaker handle remains fixed in the vertical position during any deployment or removal operation. When shipping, ensure bridge is in the flat position, the breaker handle is horizontal and that any auxiliary handles are present – these combine with the transit case foam to prevent the Pipescan HD from moving during transit. Please refer to Section 5 for instructions on safe deployment and removal.

- **Magnetic Attraction**

Due to the strong magnetism involved, the Pipescan HD system will be attracted to any ferrous material in the vicinity. Loose tools and other small objects containing iron will be strongly attracted by the system and may cause injury as they move towards the poles. Always ensure to work in a clean area, carefully follow handling instructions and be vigilant.

- **Pacemakers or other medical devices and mechanical implants**

Powerful magnets may interfere with medical electronics such as pacemakers, defibrillators or other internal and external medical devices. **The interference can be severe and cause malfunctions.** Individuals wearing such devices should be careful when handling strong magnets. If any user has any type of electronic, mechanical, implanted or external medical device, they should consult a physician and the manufacturer of the medical device to determine its susceptibility to static magnetic fields prior to allowing them to handle the Pipescan HD. All magnetic products should be kept at a safe distance from individuals with such devices.

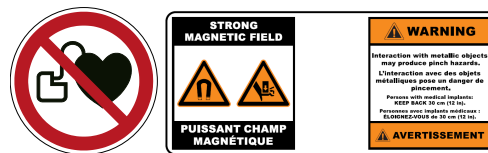

- **Damage to magnetic media, electronics, and mechanical devices**

Any form of credit card, security pass, computer or programmed equipment may be permanently affected if exposed to the powerful magnetic field of the unit. When the Pipescan HD head is not in use, a keep plate (included in transport case) should be used to store the unit.



## 1.3 Conventions

### Scanning direction

The Pipescan HD system is directional. The scanning head should be moved in the same direction during the inspection as during system set up. A label indicating the scan direction is located on the Pipescan HD, on the same module as the control buttons.

### Scanning speed

The Pipescan HD system is encoded, reducing speed dependency. When working close or above the recommended wall thickness, the system can become more speed sensitive as the thickness of material to saturate increases.

In addition, even if speed dependency is reduced, Magnetic Flux Leakage (MFL) technique can be sensitive to speed variations during scan. Keeping a constant speed during acquisition will improve data quality, as well as avoiding to stop and go during a scan.

Scanning speed should not exceed 1 m/s (3.28 ft/s) in any case, but keep in mind that lower speed might provide better results in some cases (thick walls, high lift-off, rough surface finish, etc.).

### Pipe diameters

All pipe diameters stated throughout this manual are real outside diameter (OD) measurements. They are not nominal pipe sizes (NPS).

### Model Variations

The latest Pipescan HD 127xFlat model is used throughout this manual for illustrative purposes.

## 1.4 Daily Pre-Scan Checks

Prior to operating the unit at the beginning of a shift, remove the Pipescan HD from the transit case and place in a safe, non-ferrous area.

For Pipescan HD 127xFlat models manufactured post December 2021, follow steps 1-6. For all Pipescan HD models manufactured pre December 2021, follow steps 3-6:

1. Check that quick-release locking pin is present and fits in all 3 locking locations (vertical, horizontal, storage).

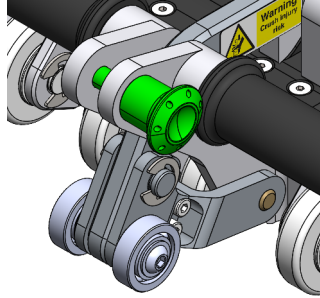

Figure 1: Pipescan HD Quick-Release Pin

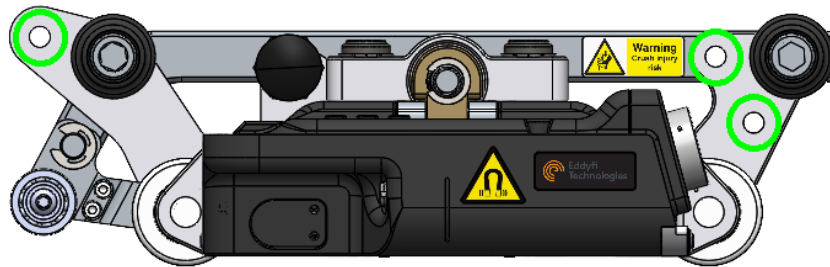

Figure 2 - Pipescan HD Quick-Release Pin Locations

2. Check that the fail-safe spring plunger operates correctly, and reliably returns to the extended position when released.

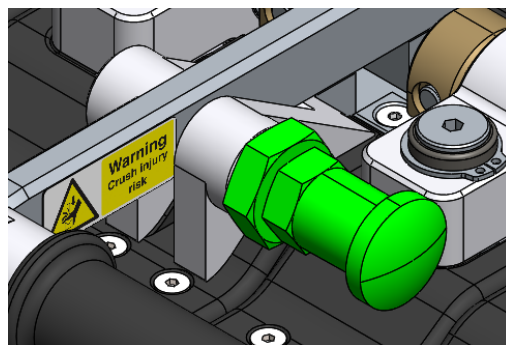

Figure 3: Pipescan HD Fail-Safe Spring Plunger

3. Check that both sides of the adjuster mechanism can be reliably operated to both fully-open and fully-closed positions using the provided adjustment tool.

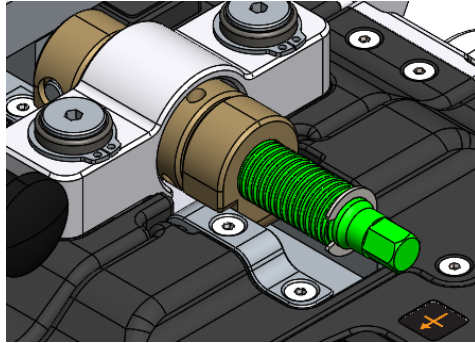

Figure 4: Pipescan HD Adjuster Screw

4. Check that the breaker arm raises and lowers smoothly to the fully-vertical and fully-horizontal positions.

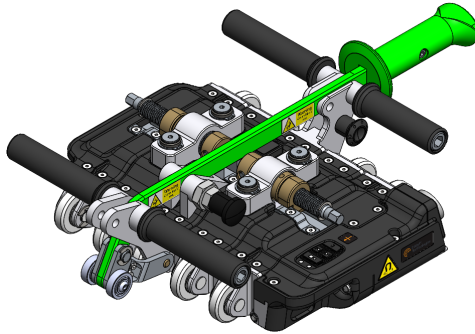

Figure 5: Pipescan HD Breaker Arm

5. Check that all wheels run smoothly and freely and that wheel brackets are clean of debris using a brush, an airline or similar if required.

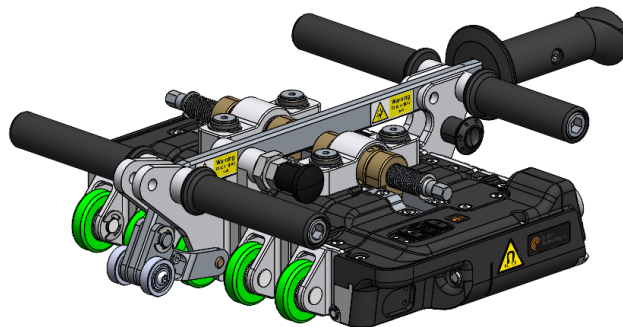

Figure 6: Pipescan HD Wheels



6. Check that the underside of the scanner is free of large pieces of debris by cleaning with a brush if necessary.

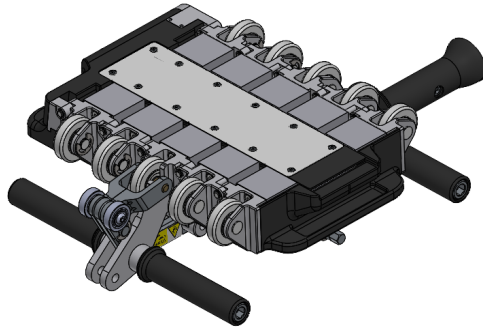

Figure 7: Pipescan HD Underside

If the system does not pass the Daily Pre-Scan Checks, the system should not be used until it can be assessed for safety and repaired if necessary. If necessary, contact [support@eddyfi.com](mailto:support@eddyfi.com) for further assistance.

## 1.5 Acronyms

ECA	Eddy Current Array
ID	Internal Diameter
MFL	Magnetic Flux Leakage
NPS	Nominal Pipe Size
OD	Outside Diameter
UT	Ultrasound
WT	Wall Thickness

Chapter 2

# Pipescan HD System Overview

## 2. Introducing the Pipescan HD Family

The Pipescan HD is corrosion screening tool for ferrous metal pipes. It is available in 3 different configurations to cover diameters ranging from 48 mm (1.9 in) to flat surfaces. Each configuration has been optimized, but not limited, for the detection of small, isolated pitting and general corrosion in coated and uncoated carbon steel pipework. The Pipescan HD is used to scan the pipe longitudinally.

Each PipescanHD is delivered in an IATA compliant transport case. A curvature adjustment tool and curvature gauge are included with The 73-127 and 127-Flat models.

Model	Intended for use on Pipework (mm)	Intended for use on Pipework (Inches)
PS-HD-MFL-127XFLAT	127 mm (OD) to Flat Surface	5.0 in (OD) to Flat Surface
PS-HD-MFL-73X127	73 mm (OD) to 127 mm (OD)	2.875 in (OD) to 5.0 in (OD)
PS-HD-MFL-48X63	48 mm (OD) to 63 mm (OD)	1.9 in (OD) to 2.5 in (OD)

The Pipescan HD requires a detachable encoder and detachable cable to link the scanning head to the acquisition unit. The same cable and encoder are compatible with all 3 models of Pipescan HD. Each Pipescan HD transport case includes room for one cable and one encoder.

Pipescan HD is compatible with Eddyfi Swift-M, Reddy or Ectane2 acquisition instruments. Instruments are briefly introduced in Section 2.

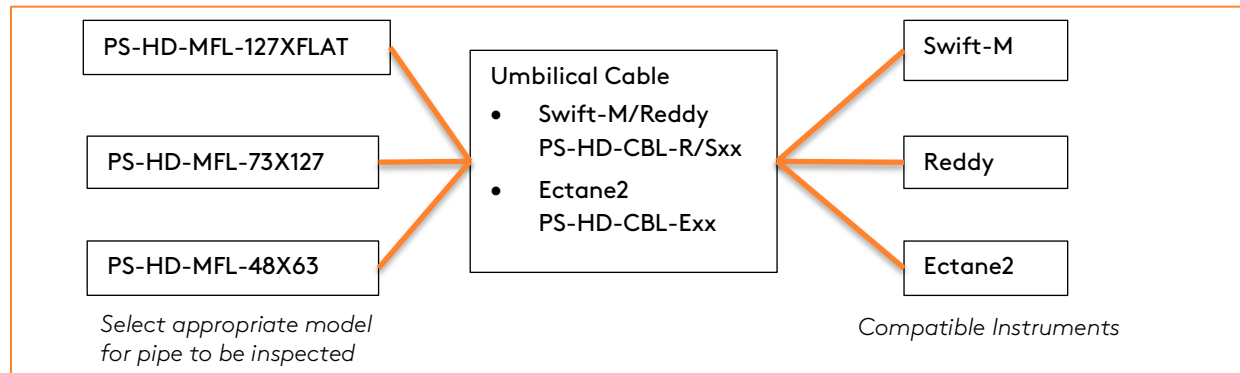

Figure 8: Pipescan HD connection overview

### 2.1 MFL technique

To detect a leaking field, the Pipescan HD uses Hall Effect sensors mounted between the poles of a magnetic bridge. The magnetic bridges include strong permanent magnets that induce a magnetic field into an inspection specimen. The presence of a defect in the inspection specimen causes the induced magnetic field to leak and it is this leaking magnetic field that the suitably placed Hall Effect sensors detect.

MFL systems are heavily reliant on the inspection surface, upon which they operate. It is important to understand that as the condition of the inspection surface deteriorates, so can the effectiveness of any MFL system. All MFL systems interpret a leaking field and any influencing factors that affect this leaking field must be understood and factored into the inspection process.



In cases where accurate remaining wall thickness is required, any defect indications reported with the Pipescan HD system should be cross-checked with an alternative method (such as UT or a pit gauge).

## 2.2 Specifications

PIPESCAN HD PERFORMANCE			
	PS-HD-MFL-127XFLAT	PS-HD-MFL-73X127	PS-HD-MFL-48X63
Technology	Magnetic Flux Leakage / Hall Effect Sensors		
Method of propulsion	Hand Push Speed up to 1 m/sec (40 in/sec)		
OD range (real value)	127 mm to flat (5.0 in to flat)	73 mm to 127 mm (2.875 in to 5 in)	48 mm to 63mm (1.9 in to 2.5 in)
Max recommended wall thickness	Up to 12.7 mm (0.5 in)*	Up to 8.56 mm (0.337 in)*	Up to 6.05 mm (0.238 in)*
Maximum coating thickness	6 mm (non magnetic material)		
Number of channels	28	18	10
Channel spacing	7 mm (0.27 in)		
Smallest detectable defect	2 mm diameter defect at 10% wall loss**		
Maximum surface temperature	60°C (140°F)		
Connecting cable	5 meter (15 feet) standard length		
Weight	29.5 lbs (13.4 Kg)	20.5 lbs (9.3 Kg)	12 lbs (5.5 kg)
Transit case	Meets IATA requirements for transporting magnetizable material		
Compatible Instruments	Silverwing Swift-M, Eddyfi Reddy-32M		

\* It must further be noted that reduced detection capability is possible on thicker inspection surfaces.

\*\* These results are based on artificial defects. Detection capabilities may vary depending on different inspection factors, for further information please contact Eddyfi.

## 2.3 Features

### 2.3.1 Pipescan HD

The below illustration is for Pipescan HD 127xFlat models manufactured post December 2021. PipescanHD models manufactured pre December 2021 will have feature differences, depending on model.

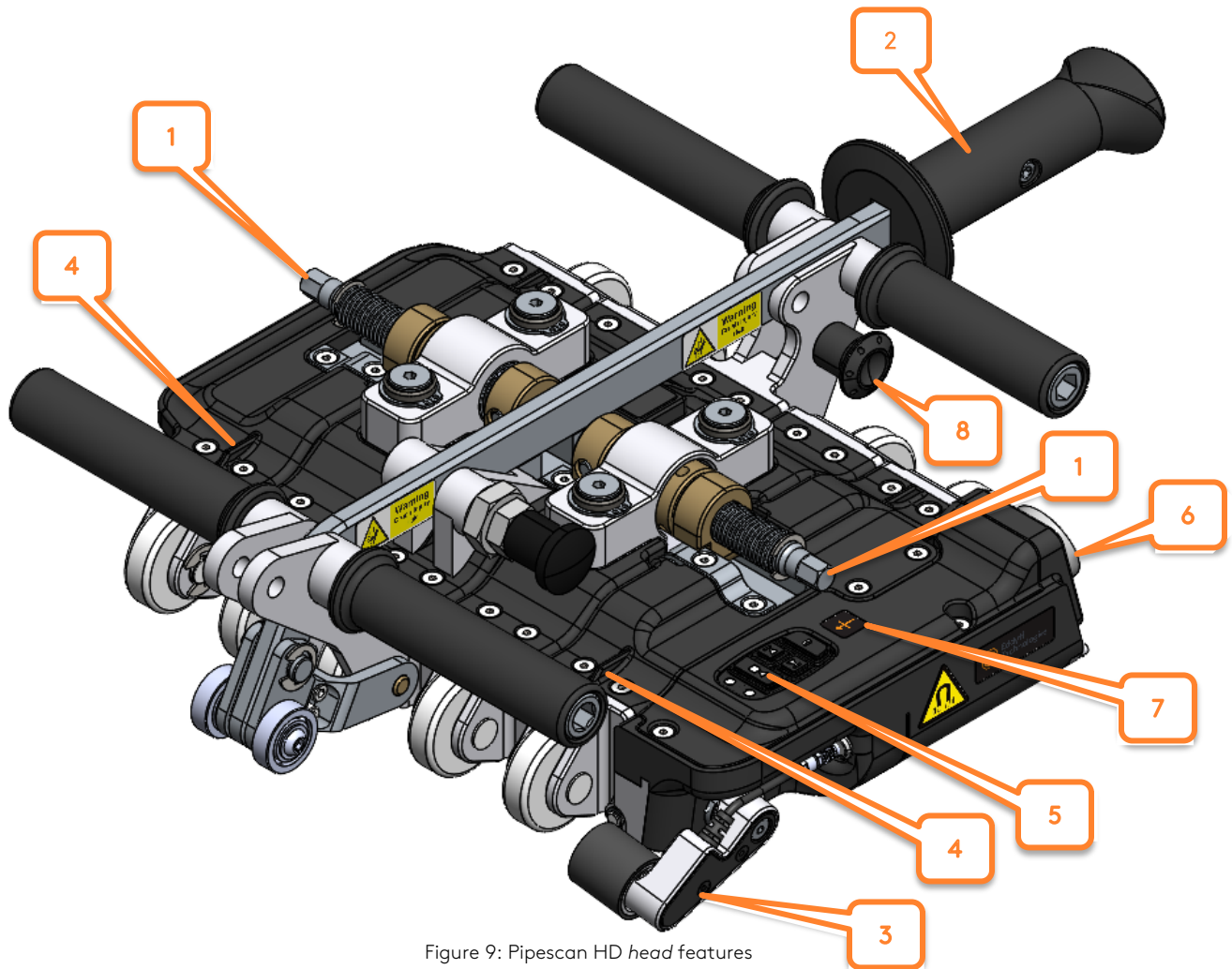

Figure 9: Pipescan HD head features

#### 1. Curvature adjustment mechanism

The curvature adjustment mechanism allows the user to adjust the curvature of the adjustable Pipescan models to match the inspection surface outer diameter. The curvature adjustment tool, supplied with the scanning head, can be used together with the curvature gauge to achieve initial set up. Once the system has achieved initial set up, it can be placed on the pipe and then fine tuning can be applied to ensure the system is free to move along the inspection surface.

The Pipescan HD should be adjusted to nominal OD while the head is not on the part to inspect. **Adjusting the curvature while on the part could damage the mechanism due to the strength of the magnets.** Final 'fine' adjustments can be completed while the PipescanHD is attached to the component being inspected.

2. Breaker handle

The breaker handle is intended for use upon deployment and removal of the Pipescan HD head.

3. Detachable encoder

An optical encoder designed to be removable.

4. Sensors positions

Position of sensor #1 and #28 (indicated by the position of the fins on the cover of the first and last bridge).

\*The top of the C-Scan displayed on the instrument corresponds to the sensor closest to the electronic module of the head.

5. Control buttons

Start, Stop, Pause and change scan line directly from the Pipescan HD.

6. Connector for detachable cable

A ruggedized port to allow for the connection between the Pipescan HD and the acquisition unit.

7. Label for scan direction and physical zero axial position

Origin of the axial position measured in the software. Also indicates the scan direction.

8. Quick-release breaker handle pin

Use for locking breaker handle in either horizontal or vertical position.



### 2.3.1.1 Pipescan HD keypad

The Pipescan HD keypad can be used to control data acquisition. Note that the Previous Pass button is only active when using an Ectane and is not associated to any action on Reddy or Swift-M.

The red LED indicates the status of the Play/Pause function. Emitting red means, the system is in Pause and the encoder is deactivated to allow for repositioning of the Pipescan HD for the next scan pass.

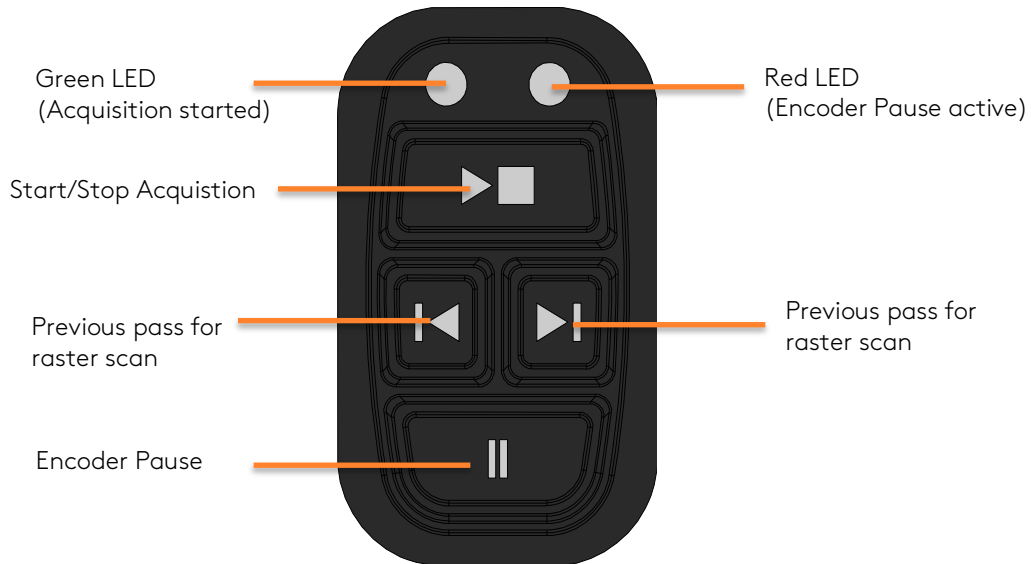

Figure 10: Pipescan HD keypad

LED	Acquisition Status	Encoder Mode	Description
	Idle	Active	No active acquisition, Encoder monitored
	Idle	Paused	No active acquisition, Encoder disabled
	Running	Active	Data and Position is captured
	Running	Paused	Pipescan HD can be realigned without disturbing recorded encoder position

Table 1: Keypad LED Status Display

### 2.3.2 Encoder - ENC-PS-HD

1. Contact wheel
2. Pivoting arm
3. Attachment bracket (Attach to Pipescan HD with 2 screws M3)
4. 4-pin Lemo connector

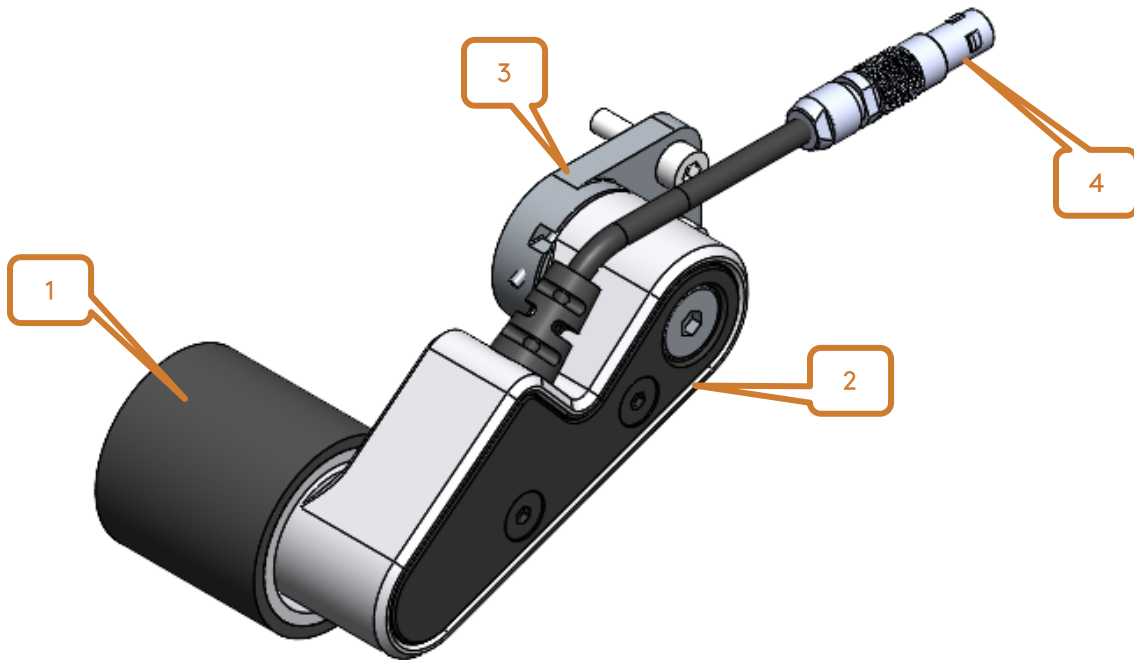

Figure 11: ENC-PS-HD features

## How to install and remove encoder from Pipescan HD

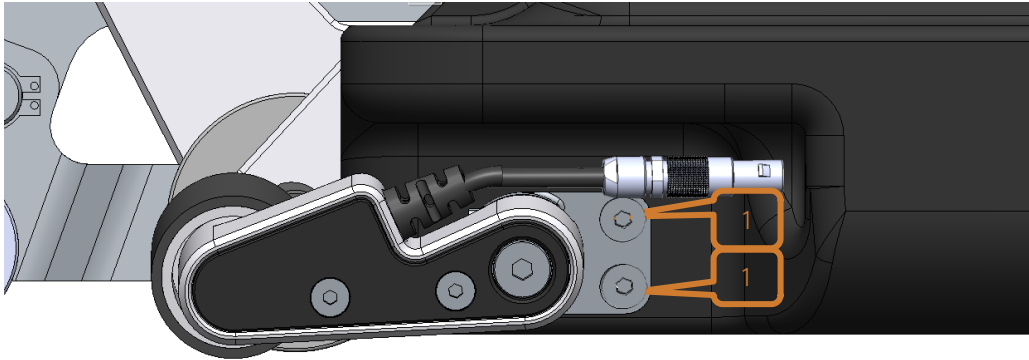

Figure 12: ENC-PS-HD installation on Pipescan HD

The encoder is fastened to the Pipescan HD on the side of the electronic module.

Install the encoder prior to installing the Pipescan HD on the inspection surface to have easy access to the slot.

To do so, position the encoder's attachment bracket in its slot and fasten using the two Allen screws (1), as shown in Figure 12.

Connect the encoder's connector. Make sure that red dots on connector and receptacle are aligned when doing so.

To remove, simply disconnect the connector and remove the two Allen screws.

### 2.3.3 Cable PS-HD-CBL-R/S05 and PS-HD-CBL-E05

1. 41-pin Amphenol connector. Head side
2. I/O connector (12-pin Fischer for Reddy and Swift-M or 18-pin Amphenol for Ectane2) – Labelled I/O
3. Signal connector (160-pin array)
4. Drive connector (19-pin Fischer for Reddy and Swift-M or 41-pin Amphenol for Ectane2) – Labelled ECT



Figure 13: Pipescan HD cable features

### 3. Acquisition Unit – Ectane2, Reddy or Swift-M

Pipescan HD is compatible with three different acquisition units. Each one is briefly introduced below for features related to Pipescan HD use only. For further details, please read the dedicated user manual of each unit.

#### 3.1 Ectane2

If using Ectane2, the minimum requirement is Ectane2-E64RNM.

Ectane2 requires the use of a laptop to run Magnifi® software. Software program and licence are not embedded in the unit. The list below introduces the connectors/button used when using the Pipescan HD system.

1. 160-pin array connector – Sensors input
2. I/O connector (18-pin Amphenol) – Encoder signal input
3. Extended ET connector (Drive connector) (41-pin Amphenol) – Drive signal for sensors
4. Ethernet connector - To communicate with laptop and software
5. Power cable connector – To charge the batteries or use without batteries
6. Power button



Figure 14: ECTANE2 face plate. Image above shows model ECTANE2-E128RNM1

## 3.2 Reddy and SWIFT-M

If using Reddy, the minimum requirement is REDDY-32M.

Reddy and Swift-M are portable units with embedded software and licence.

1. 160-pin array connector – Sensors input
2. I/O connector (12-pin Fischer) – Encoder input
3. ECT Drive connector (19-pin Fischer) – Drive signal for sensors
4. Quick copy USB port - Setup import/export, data export, etc.
5. Additional USB 2.0 ports; to plug USB devices to the Reddy (mouse, external disk drive)
6. Power cable connector - To charge the batteries or use without batteries



Figure 15: Reddy and Swift-M left side views





Figure 16: Reddy and Swift-M right side views



Figure 17: Reddy and Swift-M front view

## 4. Software: Magnifi, Magnifi GO and Swift-M GO

The minimum software version compatible with the Pipescan HD system is Magnifi 4.6R14 (Ectane2), Magnifi GO 4.6R14 for Reddy and Swift-M-Go 1.0R14 for Swift-M.

Swift-M GO is a MFL dedicated version of Magnifi. Workflow to perform inspection is detailed in section 9.1.

For Ectane2 and Reddy systems, minor differences between the desktop version and portable version exist but a single procedure is applicable for the use of Pipescan HD (Section 9.2).

The subsection below provides information on the layout features and data management that will be required when using the Pipescan HD system. This information is common to all software compatible with Pipescan HD.

### 4.1 Layout



Figure 18: Pipescan HD standard acquisition and analysis layout

1. Datafile list: Display the list of datafiles (acquired or to be acquired if list was created beforehand).
2. MFL C-scan: Display the MFL data obtained during scans in a 2D color map.
  - a. Add indication: Click to manually add a defect in the report. The added defect box will appear as per dimensions and position of the cursor on the C-scan view.

- b. Color palette adjustment: Swipe up/down to adjust the color palette threshold.
  - c. Indication box: Automatic detection box highlighting all indication exceeding the threshold set in the horizontal strip chart. Detections are not automatically added to the report. To do so, refer to the *Analysis* section further in this document.
3. Horizontal strip chart: Superimposed strip charts, each of them representing 1 individual channel. The display is used to show the profile of the indications and to set the detection threshold. Single or cursor render are also available.
- a. Detection threshold: Click on the bold red line to adjust the detection threshold. All indications exceeding this threshold will be highlighted by a detection box in the C-scan (yellow box).
4. Info fields:
- a. Center X (mm): Display the current position of the cursors in the C-scan in the scan axis direction (X-axis)
  - b. Delta X (mm): Display the width of the cursors in the C-scan in the scan axis (X-axis)
  - c. Center Y (mm): Display the current position of the cursors in the C-scan in the index axis direction (Y-axis)
  - d. Delta Y (mm): Display the height of the cursors in the C-scan in the index axis (Y-axis)
  - e. MFL amplitude (V): Display the signal amplitude measured in the MFL C-scan at the cursor position.

**Note:** To change the settings of any of these windows, select it and go to the *Current View* menu.

Chapter 3

# Getting Started

## 5. Getting Started

### 5.1 Set up Your Pipescan HD System

Always remember to follow the general and safety precautions related to this product, as detailed in Section 1.

Adjust the head curvature to the desired diameter. Always make the primary adjustment away from the part to ensure longevity of the curvature mechanism. Fine-tuning can be done with the Pipescan HD installed on the pipe when needed. The system can be adjusted either with the gauge or a ruler.

1. **Adjustment using the gauge included with the system:** Place the gauge between the outer posts and tighten until the posts touches the gauge. Repeat on the other side of the system.

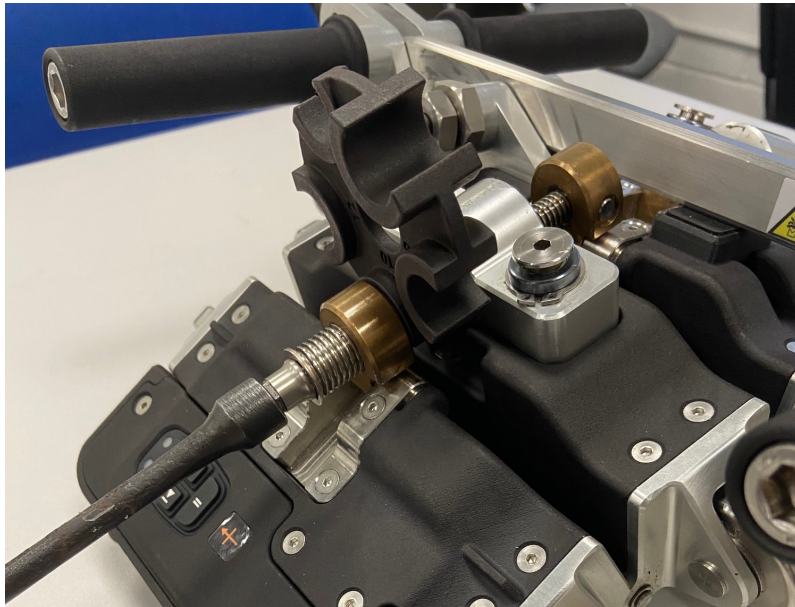

Figure 19: Pipescan HD curvature adjustment

2. **Adjustment using a ruler:** If the gauge is not available or if the diameter required is not shown, use a ruler and the table below to adjust the system. The measurement must be taken between the outer posts, on each side of the system. Refer to the table below for the adjustment details.

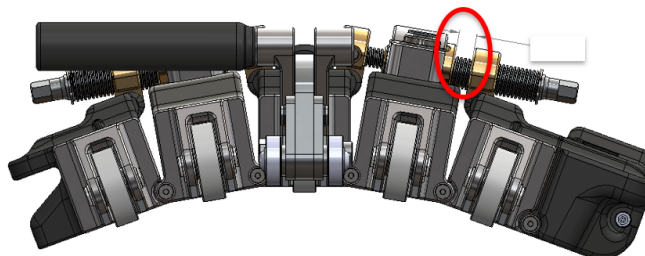

Figure 20: Pipescan HD curvature adjustment using a ruler

Once the adjuster system diameter has been approximately set, the system can be deployed onto the inspection surface. Please refer to the next section on deployment & removal.

Model	Pipe nominal OD	Real OD	Distance between posts on Pipescan HD head
	NPS	[in / mm]	[in / mm]
PS-HD-MFL-48X63	1.5	1.9 / 48.26	To max open position
	2.0	2.375 / 60.33	0
PS-HD-MFL-73X127	2.5	2.875 / 73.03	0.543 / 13.8
	3.0	3.5 / 88.90	0.378 / 9.6
	3.5	4.0 / 101.6	0.276 / 7.0
	4.0	4.5 / 114.3	0.189 / 4.8
PS-HD-MFL-127XFLAT	4.5	5.0 / 127.0	1.15 / 29.2
	5	5.563 / 141.30	1.067 / 27.1
	6	6.625 / 168.28	0.937 / 23.8
	7	7.625 / 193.68	0.839 / 21.3
	8	8.625 / 219.08	0.76 / 19.3
	9	9.625 / 244.48	0.697 / 17.7
	10	10.75 / 273.05	0.634 / 16.1
	12	12.75 / 323.85	0.547 / 13.9
	24	24.0 / 609.6	0.319 / 8.1
	36	36.0 / 914.4	0.224 / 5.7
	48	48.0 / 1219.2	0.177 / 4.5
	Vessel 6ft	72.0 / 1828.8	0.130 / 3.3
	Vessel 4ft	96.0 / 2438.4	0.106 / 2.7
	Vessel 10ft	120.0 / 3048	0.091 / 2.3

Table 2: Adjustment details when using a ruler to adjust system's curvature

## 5.2 Deployment & Removal

Due to the powerful magnets involved, the breaker handle used to deploy and remove the Pipescan HD head from the surface can exhibit a strong downward force and presents a finger trap. The user must be in control of the breaker handle at all times. It is important to follow the correct deployment and removal procedure for the Pipescan HD system. Failure to do so could cause damage to the scanning head or cause injury to the operator. **Care must always be taken** when handling and using the Pipescan HD system.



## 5.2.1 Deployment

### Pipescan HD 127xFlat Models manufactured post December 2021

1. Away from any ferromagnetic surfaces, set the breaker handle to the vertical position and add the quick-release pin to retain the breaker handle.

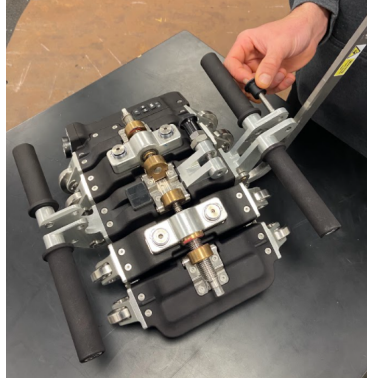

Figure 21: Pipescan HD Deployment 01

2. Hold the Pipescan HD firmly by the breaker handle and the front carry handle.

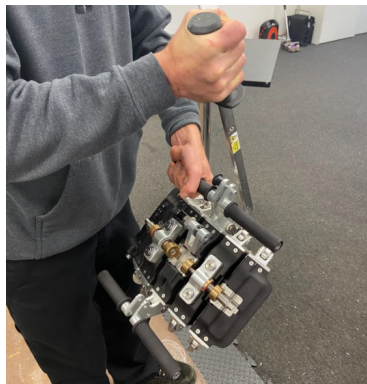

Figure 22: Pipescan HD Deployment 02

3. Whilst maintaining a firm grip of the breaker handle and front carry handle, carefully place the rear rollers onto the inspection surface.



Figure 23: Pipescan HD Deployment 03



- Maintaining the breaker handle in the upright position, slowly lower the front of the Pipescan HD so that the breaker handle bearings engage with the inspection surface.



Figure 24: Pipescan HD Deployment 04

- Remove the quick release pin and gently lower the breaker handle in a controlled manner to allow the system to make full contact with the inspection surface.

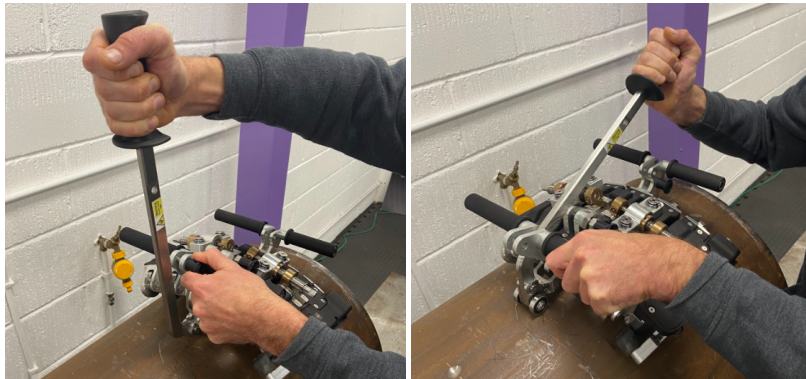

Figure 25: Pipescan HD Deployment 05

- Pull the index plunger to allow the breaker handle to sit at the full horizontal position. Place the quick release pin in the retaining hole slot or in the breaker handle lock position, if desired.



Figure 26: Pipescan HD Deployment 06

## Pipescan HD models manufactured pre December 2021

1. Away from any ferromagnetic surfaces, set the breaker handle to the vertical position.
2. Hold the Pipescan HD firmly by the breaker handle and the front carry handle.
3. Whilst maintaining a firm grip of the breaker handle and front carry handle, carefully place the rear rollers onto the inspection surface.
4. Maintaining the breaker handle in the upright position, slowly lower the front of the Pipescan HD so that the breaker handle bearings engage with the inspection surface.
5. In a controlled manner, gently lower the breaker handle to allow the system to make full contact with the inspection surface. **Extreme care must be taken when operating the breaker handle.**

### 5.2.2 Removal

#### Pipescan HD 127xFlat Models manufactured post December 2021

1. Hold the Pipescan HD firmly by the front carry handle and the breaker handle. In a controlled manner, lift the breaker handle to the vertical position. Add the quick-release pin to retain the breaker handle.

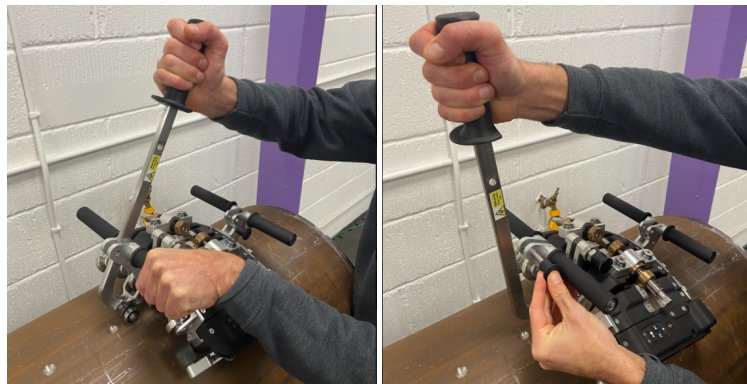

Figure 27: Pipescan HD Removal 01

2. Holding the Pipescan HD by the front carry handle and breaker handle, lift the scanner vertically away from the inspection surface.



Figure 28: Pipescan HD Removal 02

## Pipescan HD models manufactured pre December 2021

1. Hold the Pipescan HD firmly by the front carry handle and the breaker handle. In a controlled manner, lift the breaker handle to the vertical position.
2. Whilst maintaining a firm grip of the front carry handle and the breaker handle in the vertical position, lift the scanner vertically away from the inspection surface. **Extreme care must be taken when operating the breaker handle.**

## WARNING

DO NOT attempt to lift or carry the Pipescan HD by the umbilical connector as damage could result.



Figure 29: Incorrect Lifting of Pipescan HD

DO NOT attempt to drag the Pipescan HD laterally across the pipe as damage may occur to the wheels and/or pipe surface.

The Pipescan HD large scanner is designed to operate on pipe diameters 127mm and larger – do not attempt to deploy the scanner on pipes lower than this diameter, as this could potentially cause damage to the system. Additionally, do not run the system over protruding obstacles (weld lines, weld splatter, steps etc.) as this will cause the scanner to ground out and potentially significant damage to the underside.

## 5.3 Connect to Your Instrument

1. Turn on the acquisition unit.
  - a. If using Ectane2, connect it to a laptop using the ethernet cable and launch Magnifi software on the computer, then connect the instrument to Magnifi using the connect



button , in the instrument ribbon

2. Connect the cable to the Pipescan HD head, then to the acquisition unit.
  - a. Connect the 41-pin Amphenol connector to the Pipescan HD head
  - b. Connect the 160-pin array connector to the 160-pin array connector on the instrument
  - c. Connect the I/O connector to the I/O or Encoders connector on the instrument
  - d. Connect the ECT connector to the ECT / Extended ET connector on the instrument

## 5.4 Create or Load Your Setup

### 5.4.1 Create a new setup

1. From the *Setup* ribbon, click on *New*.
  - a. Magnifi and Magnifi GO users will then required to select *MFL Surface Setup*
  - b. Swift-M users go straight to step 2

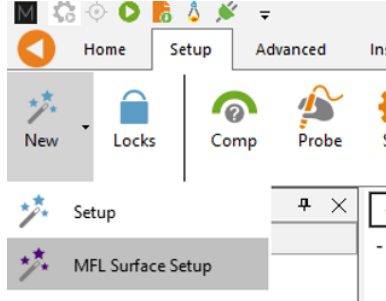

Figure 30: Create new MFL Surface setup in Magnifi and Manifi Go

2. Select the probe setup corresponding to the probe in use. Then click *Next*



Figure 31: New MFL setup - Probe Selection

3. Configure the size of the scan and display properties

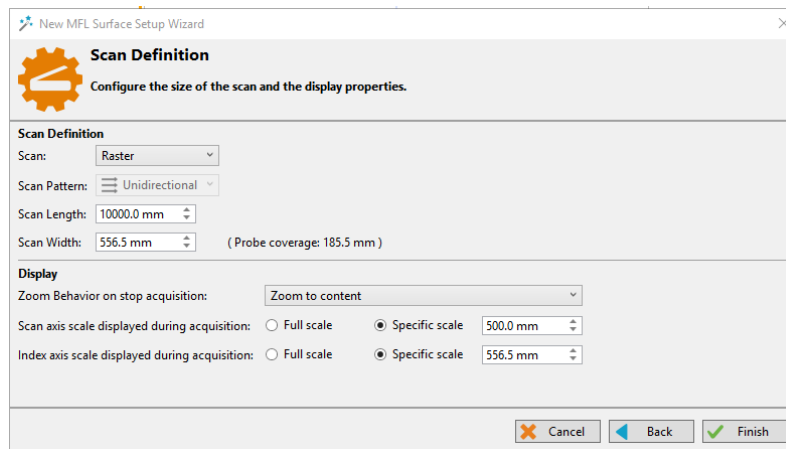

Figure 32: New MFL setup - Scan Definition

- a. Scan type:
  - i. Single pass: One-line scan
  - ii. Raster scan: Allows for unidirectional raster scans using a single encoder (click to index)
- b. Scan length: Define the maximum length of your scan. **If a longer distance is scanned, all data exceeding the defined scan length will not be displayed or recorded by the system.**
- c. Scan width (only with raster scan): Define the total width of the scan (e.g.: total circumference of the pipe ).
- d. Zoom behavior on stop acquisition: On stop acquisition, software can display only a section of data, the entire set of data (if smaller or equivalent to scan length) or the entire scan length previously defined.
- e. Scan axis scale displayed during acquisition:
  - i. Full scale: During acquisition, will display the entire length of scan configured in step b
  - ii. Specific scale: During acquisition, Magnifi will display only the last portion of scan corresponding to the length entered in the field
- f. Index axis scale displayed during acquisition (Only with raster scan):
  - i. Full scale: During acquisition, will display the entire length of scan configured in step b
  - ii. Specific scale: During acquisition, Magnifi will display only the last portion of scan corresponding to the length entered in the field

4. Click *Finish*.

The default layout will then be displayed on the screen as shown. For all users, layout can be modified from the *Layout* ribbon.

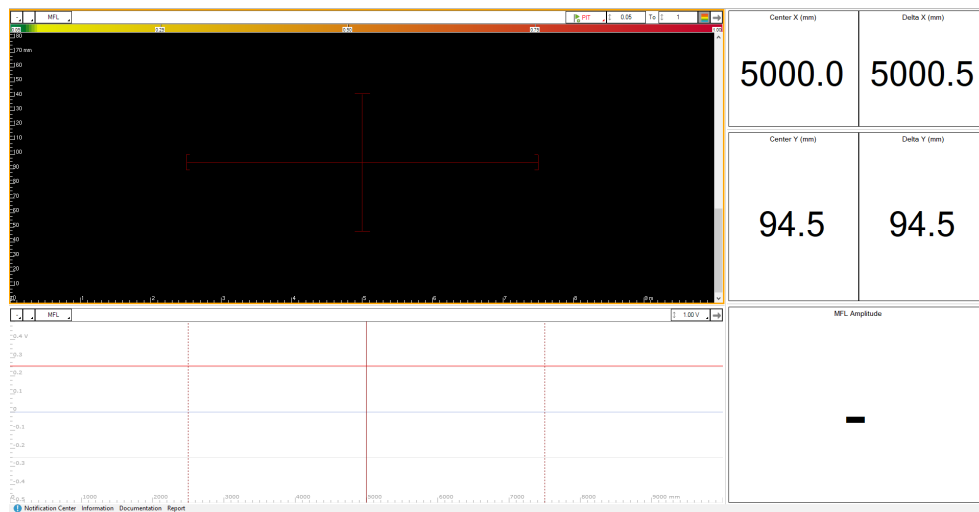

Figure 33: Default layout created from the setup wizard

If needed, the different steps of the wizard can also be accessed individually from the setup tab:



Probe selection: Selection of the Pipescan HD being used. The probe reference name is indicated on the side of the Pipescan HD, on the electronic module.



Scan definition: Configuration of the scan parameters:

- Scan type (single pass or raster)
- Scan length and width
- Display behavior during and after acquisition



Indication codes: Managing the different types of indication codes used for the indications added manually to the report.

**Reddy and Ectane 2 users:** The setup file can be *Saved as...* If any modifications are done to the original setup file (e.g., color palette, threshold, etc.), it will be saved in this new setup file and it can be reloaded for future inspection by following the steps of the section below.

## 5.4.2 Load existing setup file – Magnifi and Magnifi GO users only

It is possible to modify the original default setup created using the MFL Surface Wizard. For example, color palette can be changed, layout can be modified, etc. In case you wish to do so, it is possible to Save as... your modified setup file and reuse it for your next inspection, when working with Reddy or Ectane2.

To load a setup file:

1. Access the Magnifi backstage
2. In the Setup / Data section:
  - a. Reddy / Magnifi GO: Click on the "..."
  - b. Ectane 2 / Magnifi: Click on *Open Setup*
3. Navigate and select the setup file you wish to use
4. Click on OK
5. Click on *Start / Resume*

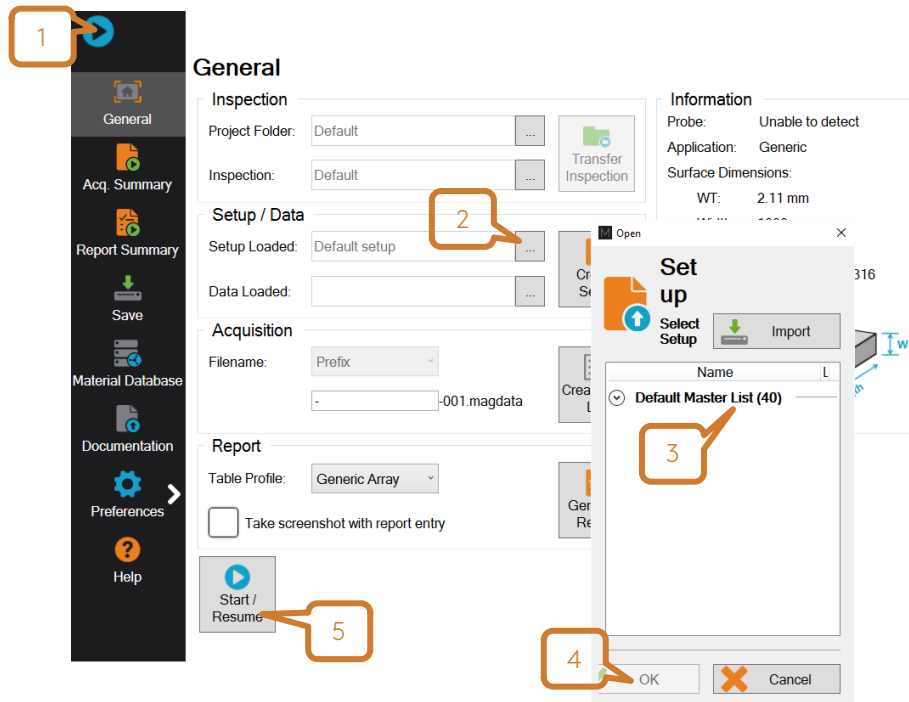

Figure 34: Load existing setup file in Reddy



## 6. Alarm Threshold Adjustment

The Pipescan HD is a high-resolution detection tool that can detect millimeter-sized pitting. Depending on the application, this can lead to hundreds of indications detected during a single scan.

To facilitate the efficient reporting of large numbers of indications, a lot of effort has been made toward the automatic detection of indications in the software. For Pipescan HD, this automatic detection is based on a signal threshold in the horizontal stripchart: indications with a signal amplitude higher than the threshold will be automatically marked in the C-scan.

Setting a threshold can determine how the software automatically identifies defects. It is important to understand that the different views display all the captured information regardless of whether a threshold has been set or not, but that indications exceeding the threshold will be marked by a yellow box in the C-scan. This ability to see all the data is vital and overcomes previous limitations of setting a hard threshold.

A threshold can be set in two ways via:

1. A Reference Sample
2. The Inspection Specimen

Detailed instructions for each case are presented below.

The threshold is a software tool and not a hard threshold. It is then possible to modify it afterward, during the analysis phase, if needed.

### 6.1 Threshold adjustment using a reference sample

**NOTE:** MFL is an inspection technique that is sensitive to volume loss. The reference flaw used for threshold adjustment needs to be representative of the minimum flaw that is considered critical for the asset under inspection. Indications highlighted by the threshold adjustment will have a bigger volume than the reference, but diameter and depth must be validated with a complementary technique. Wall thickness of the reference sample shall also be the same / representative of the component under inspection. Furthermore, the material composition should be such that the inspection specimen and reference specimen are similar.

1. Set the Pipescan HD system up as desired i.e. confirm setup and probe and adjust curvature.
2. Install the head on the sample on a section known to be free of any indications.

3. Start an acquisition by clicking on the *Acquire*  button in Magnifi or the play/stop button on the probe.

4. Scan the reference sample, then press Stop  .
5. Select the Strip chart view, then, in the Current View ribbon, make sure the Edit Alarm function is activated (greyed).

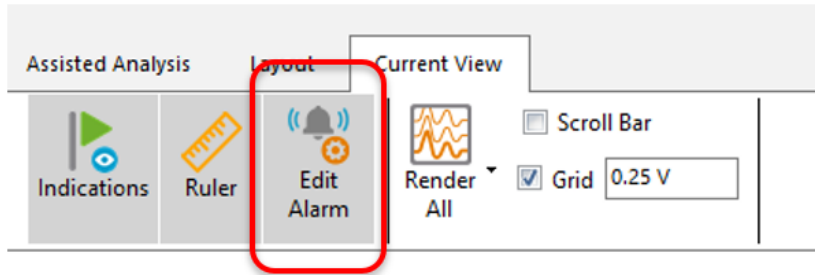

Figure 35: Edit Alarm Activation



6. In the horizontal strip chart, click-and-drag on the red threshold line and adjust it slightly below the tip of the target indication.
7. When doing so, all indications with a greater amplitude will be highlighted by yellow indication boxes in the C-scan for fast reporting.
8. If needed, the datafile can be saved in the inspection folder by clicking on Save Data As...



Save Data As... , from the Home ribbon.

## 6.2 Threshold adjustment based on background noise

When no reference sample is available, threshold can be adjusted using the background noise of the part to inspect.

1. Set the Pipescan HD system up as desired i.e. confirm setup and probe and adjust curvature.
2. Install the head on the part to inspect on a section that is known to be free of corrosion and pitting (if possible) or on an area where corrosion is more unlikely to appear.
3. Start an acquisition by clicking on the *Acquire* button  in Magnifi or the play/stop button on the probe.
4. Perform a one-line scan on the part, then press *Stop*  .
5. Select the Strip chart view, then, in the *Current View* ribbon, make sure the *Edit Alarm* function is activated (greyed) – Ref Figure 18.
6. In the horizontal strip chart, click on the threshold line and adjust it slightly above the background noise of the part. The image below provides an example.

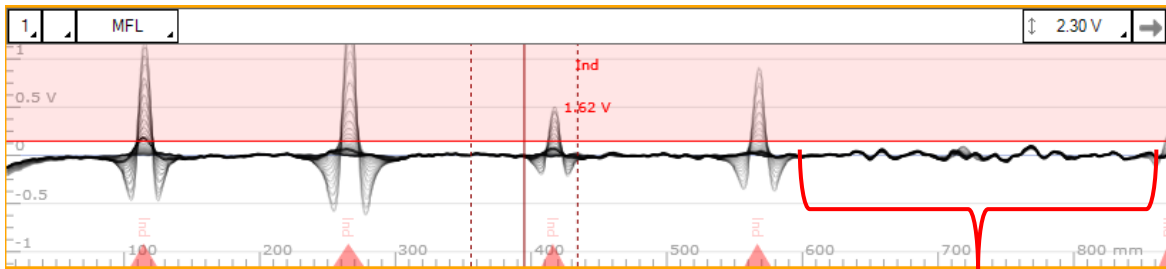

This area of the part had a rough surface finish inducing more background noise in the scan. Adjusting the threshold above this noise will avoid false calls.

Figure 36: Threshold adjustment on background noise

7. If needed, the datafile can be saved in the inspection folder by clicking on *Save Data As...*



*Save Data As...*, from the *Home* ribbon. This is a manual save and will not use one of the files created in the file list.

## 7. Color Palette

The software allows the user to change the color palette to suit the inspection parameters (adjust to different wall thickness, indication sizes, noise level, etc.). The color palette is useful to control what is seen on the C-scan: the color palette does not affect the detection capability; it merely displays the signal response between a set boundary. It is however important to understand that when a color palette is set, indications can be hidden from view.

Again, as with setting the Alarm Threshold, the cursor can be used to determine the color palette boundaries.

The colour palette is set by:

1. Perform an acquisition (Ref section 6.1, step 1 to 5)
2. Determine the low value of the color palette: The lower value of the color palette can be adjusted to simply hide the background noise or all indications below the threshold line, for example. The value can be determined using the horizontal strip chart view. In the figure below, noise level is around 0.125V.



Figure 37: Using the strip chart to determine low value of color palette

3. Once the low value is determined, click and drag low value button in the C-scan header until it reaches the desired number

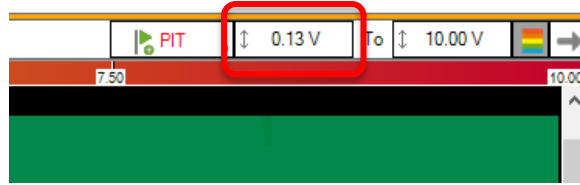

Figure 38: Click-and-drag to adjust low value of color palette

4. To adjust the high value, click-and-drag on the button on the right. The high value should be adjusted to get the desired contrast between indications of different sizes. Setting a color palette too tight will prevent a proper discrimination between indication volume, while setting a palette too large might hide some smaller indications.

**Note:** for initial setup it is recommended that the lower limit colour palette is set at a minimum (0.00v) to ensure that all data is captured and displayed, especially if small diameter defects are possible / expected.

## 8. Scan zone definition

Regardless of the surface being inspected, a scan zone should always be defined before starting an acquisition, to facilitate the tracking of the defects location and to ensure that the entire surface will be inspected without any remaining unscanned surface. This section of the user guide presents an example of recommended reference scan zone.

The scan zone is defined by the following two parameters:

1. The datum reference:

The parameter to define is the circumferential and axial origin of the scan zone. For the specific case of a pipe:

- The circumferential origin is typically set on top of the pipe, at 0° (12 o'clock). A chalk line or measuring tape can be used to draw the 0° line along the whole length of the pipe. During the first scan, the left marker (aligned with the middle of the left wheel) should be aligned with this line.

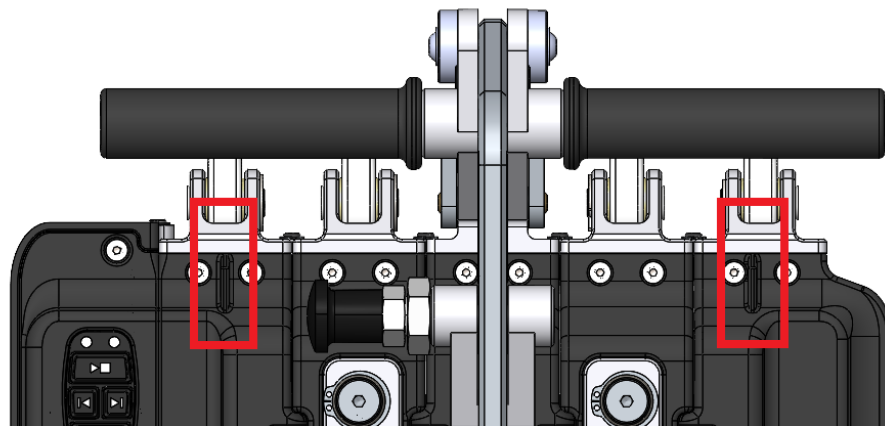

Figure 39: Casing marks must be in line with the datum line for the first scan. It corresponds to the first channel position

- For pipes, the scan direction is typically oriented with the flow. To set the axial origin, the Pipescan HD should first be placed on the pipe at the start position of the scan. To ensure that each scan will start at this exact axial position, a full circumferential line should be drawn aligned with the center line of the sensors (Sticker showing an orange cross below the keypad). In the software, the middle line of the sensors will correspond to  $X = 0$ , and will be located at the left end of the screen (beginning of the C-scan).
- Often if full circumferential scanning is required the scan width is also physically drawn on the pipe. If the scan width is known, the Pipescan HD head can be positioned to ensure optimal scanning efficiency.



Figure 40: The X and Y datum lines should be defined prior to beginning an inspection

Even though the example above is specific to pipes, the same principle can be applied to most geometries.









Chapter 4

# Acquisition and analysis

## 9. Acquisition

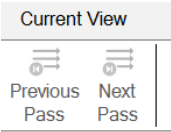
### 9.1 Performing an acquisition with SWIFT-M GO

Now that the Pipescan HD, setup file, threshold and color palette are set up, inspection work can begin. Note that identification / marking of the component to highlight areas of interest can be done at different moments: As you go during scanning, at the end of a scan or at the end of a job. All three methods are explained in the *Analysis and reporting* section of this document.

1. Place the Pipescan HD on the first section to scan, at the zero position
2. From the *Home* ribbon, start an acquisition  (or the start/stop  button on the head).
3. Scan the component.
4. Once scan line is completed:
  - a. If performing a Single line scan: Press  (or via the stop button on the head)
  - b. If performing a Raster scan:
    - i. At the end of each scan and before moving to the next track, pause the scan using the 'Pause' button on the scanner .
    - ii. Press *Next Pass* button  in the software or on the Pipescan HD .
    - iii. Position the Pipescan HD for the next track and press the 'Play' button  to resume scanning.
    - iv. Once all the scanlines to complete the raster scan are done, press stop  (or via the stop button on the head)
5. If needed or when applicable, save the data file by clicking on the *Save Data As...* button in the *Home* ribbon. 





## 9.2 Performing an acquisition with Magnifi or Magnifi GO

### 9.2.1 Data Management

This section suggests a convenient way to manage and save automatically large numbers of datafiles during an inspection. The following steps can be done in advance, before getting to the inspection site.

The terms *backstage* and *frontstage* used in this section refer to the two main windows of Magnifi. To switch between the backstage and frontstage, click on the triangle icon at the top left of the screen: 

. The backstage is displayed at the opening of Magnifi and contains the options related to the inspection, data management and general preferences. The frontstage is the main window for acquisition and analysis.

1. In the backstage, in the *Inspection* section, select a project folder and an inspection folder .
2. In the *Acquisition* section, select the *Prefix* filename option.
3. Click *Create New List*.

Select the prefix for the files name, the number of elements (i.e. data files) in the list, the index for the first data file and the index increment between each file. The example below shows an example of list based on the following selected parameters:

Prefix:	MFL
Number of elements:	4
Element start number:	10
Element increment:	2

4. Click Create.

5. In the frontstage, in the *Layout* menu, make sure the *Data*  button is checked. The datafile list as seen above will be displayed on the left side of the screen.

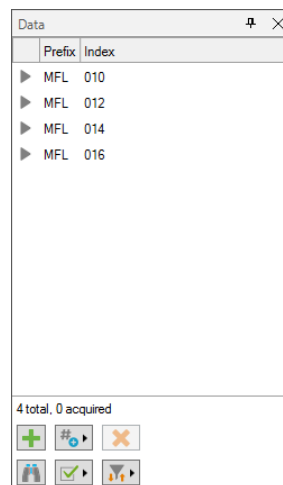



Figure 41: Data file list example





6. At the bottom of the datafile list, click *Acquisition preferences* , and check the two following options:
  - a. Automatic file recording
  - b. Automatic Next on Stop Acquisition



When an acquisition is stopped, these two options allow to automatically save the datafile and select the next one in the list. The user can then start the next acquisition, without any other manual action required in the software.



7. In the datafile list, select the first file to be acquired. The inspection can then begin.

A few more information about data management:

- The small icon beside each datafile indicates its current state:

Icon	Definition
	The datafile was acquired and saved, but has not been analyzed yet
	The datafile was acquired, saved and analyzed, and it was reported as being defect-free
	The datafile was acquired, saved and analyzed, and defects have been reported
	The datafile has not been acquired yet (empty file)
	The datafile is tagged for further review

- At any time during the inspection, the user can click *Add data*  or *Delete data*  at the bottom of the datafile list. Datafiles added with this button will keep the same prefix, and their index will be incremented by the number selected in the index menu . To create datafiles with a new prefix, go back to the backstage and click *Create New List*.
- To re-scan a datafile that has already been acquired and saved select the data file and



click *Re-scan* . To choose whether the original datafile should be kept or erased, select the corresponding option in *Acquisition preferences* .

### 9.2.2 Acquisition



By default, the Pipescan HD setup is set to single pass acquisition. In this mode, each axial scan will be recorded as a separate data file. The only relevant parameter is the scan length (X-axis), which can be modified in Setup → Scan. With the default resolution of 2 samples/mm (50 samples/inch), the maximum scan length for a single data file is approximately 75 / 100 meters (246 / 328 feet).

Now that the Pipescan HD, setup file, threshold and color palette are set up, inspection work can begin. Note that identification/marketing of the component to highlight areas of interest can be done at different moment: As you go during scanning, at the end of a scan or at the end of a job. All three methods are explained in the Analysis and reporting section of this document.

To perform a single-pass acquisition:

1. Place the Pipescan HD on the first section to scan, at the zero position
2. From the *Home* ribbon, start an acquisition  (or the start/stop  button on the head).
3. Scan the component.
4. Once scan line is completed:

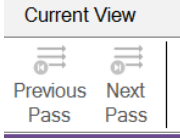
- a. If performing a Single line scan: Press  (or via the stop button on the head)

- b. If performing a Raster scan: Press *Next scan* button  in the software or on the Pipescan HD 

Please note that the encoder is still live when the next scan is performed and so care is required when placing the scanning head.

- i. Once all the scanlines to complete the raster scan are done, press stop  (or via the stop button on the head)
5. Save data as...
    - a. If automatic recording and Next file on stop acquisition have been configure prior to starting the inspection, the data is already saved in the selected folder and system is ready to start next acquisition
  6. If automatic recording is not enabled and data file need to be saved, click on the *Save Data As...*



button in the *Home* ribbon to manually save it.

## 10. Analysis and reporting

The MFL Pipescan HD tool is an advanced **screening** tool allowing for fast identification of areas of interest where probable corrosion / pits are present. As previously mentioned, there are 3 different ways to mark the areas of interest detected with the Pipescan HD. The following sub-sections describe what they are and how to proceed for each of these methods.

### 10.1 Marking as you go

When data saving and archiving is not required and on the spot proofing can be performed, marking the component as you go is an effective way to work. This means that the operator will mark, with a Sharpie or chalk, for example, the component while scanning when the signal exceeds the threshold.

For this technique to work, the threshold line must be set prior to starting the acquisition (refer to section 6). It is also recommended, if for any reason it is decided to save the data file, to rescan the component without the back and forth movements.



To mark the component as you scan it:

1. While scanning, keep an eye on the instrument screen for any indications exceeding the threshold line (Note that yellow indication boxes in the C-scan will only appear at *Stop acquisition*. For “on the go” marking, the red threshold line in the Strip Chart is the reference).
2. When an indication signal goes above the threshold line, back up the Pipescan HD so that the red vertical cursor is behind it.
3. Start moving forward again, slowly, until cursor is on top of the indication. This is the actual position of the indication.
4. Continue scanning. Repeat step 1, 2, and 3 when needed.

### 10.2 Marking at the end of each scan

Another effective way to work is to mark the component after stopping the acquisition. For this method to properly work, datum needs to be clearly marked on the pipe, as it will be used as the reference point for this method. For this technique, the threshold line can be adjusted before or after the acquisition is performed.

To mark the component at the end of each individual scan:

1. Make sure the threshold line is set as per the inspection requirement.
2. Starting at the axial zero position (extreme left of the C-scan image), select the first indication highlighted with a yellow box in the C-scan. You can manually place the cursor on the box or use the *Previous*  / *Next*  indication selection buttons from the *Analysis* ribbon.
3. Using a measuring tape and starting from the datum line on the component, mark the position of the first indication on the component by using the position displayed in the *Center X* info field box.

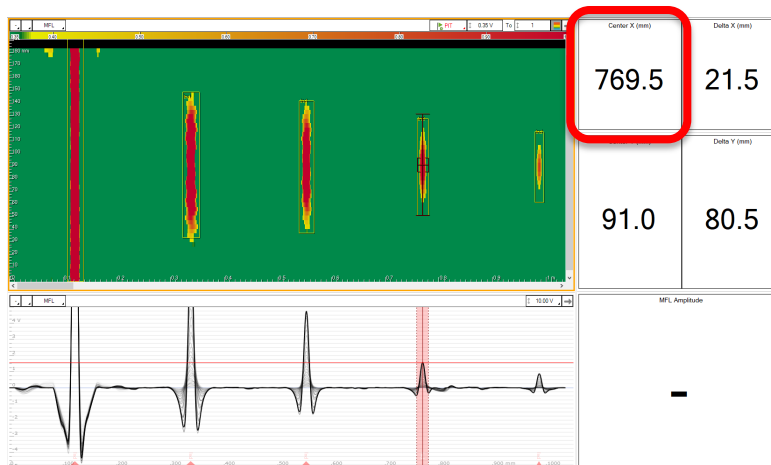

Figure 42: Getting the axial position of an indication in analysis mode

- Repeat step 2 and 3 for each indication highlighted in the C-scan image.

### 10.3 Generate a report (and mark at the end of the inspection if needed)

The third method consists in scanning all the components listed in the scope of work, without marking them during the job. At the end of the job, a report listing all the indication is generated, providing information on their position in a comprehensive table.

The threshold tool and automatic detection boxes speed up the reporting of those areas.

The steps below explain how to create a report that will provide the position of the indication on the actual part (position on the scan and index axis).

The image below is used as an example to explain the steps to automatically generate the report. This datafile shows 4 indications with a diameter of 22 mm and a depth of 20%, 40%, 60% and 80% of the wall thickness. The threshold line has been adjusted so that the 20% indication is not reported, only what has a greater volume will be highlighted in the C-scan.

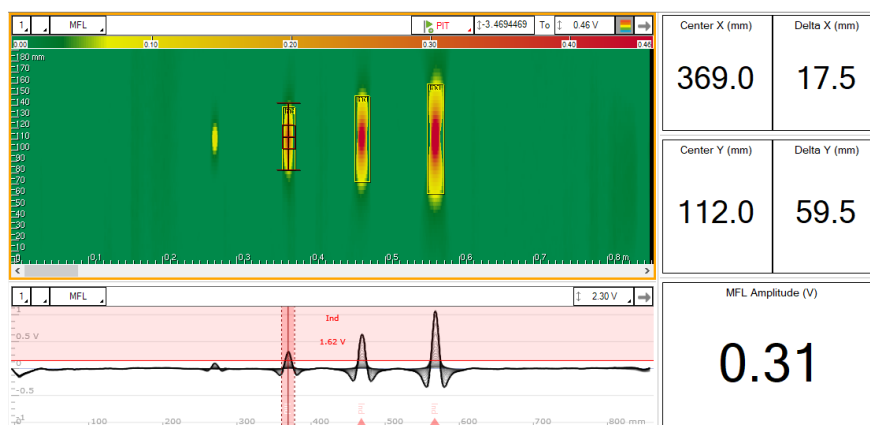

Figure 43: Example of data - How to generate report

- In the backstage, in the *Report* section, create a new report for the inspection, in the *Name* box.
- In the *Table profile* drop-down menu, select *Surface screening*.

3. Go back to the frontstage.
4. Once the threshold position is confirmed, go in the *Analysis* ribbon.



5. Click on *Report Detections*. This will add all indication highlighted by a yellow box in the report.
6. Open the report (In the *Layout* ribbon, make sure that the *Report* is activated, then open the report by clicking on the small *Report* tab at the bottom of the screen.



Figure 44: Example of report entries as seen directly in Magnifi

The report provides the following information:

- Filename: indication from all files of the inspection folder can be added in the same report.
- Index: Numerical increment for each indication added to the report (automatically generated by the software, cannot be modified).
- Code: All indications automatically detected by Magnifi will be called *Ind*. If defects are manually added to the report, the code name will be the one selected by the analyst when adding the entry.
- Channel/C-scan: Indicates from which view the indication comes from.
- X pos. (mm): Gives the center position of the indication in the scan direction, from the zero position of the scan.
- Y pos. (mm): Gives the center position of the indication on the index axis, from the zero position of the scan.
- X length (mm): Gives the width of the indication box.
- Y length (mm): Gives the height of the indication box.
- Comments: This field is editable. Operators or analysts can type comments if needed (e.g. add depth value after UT proofing).

**Note:** The screenshot function is not available for the indications that are automatically reported by software. To be able to use the screenshot function, the indications shall be converted into defects by adding defects manually in the report.

## 11. Storage & Transportation

The transport case contains an integrated keep plate to retain the magnetic field. This transport case **must** be used for safe storage and transportation. To store the Pipescan HD in the transit case, the following steps must be taken:

1. Ensure that the diameter adjuster mechanism is set so that the system is completely flat.
2. If supplied, ensure at least 3 of the 4 auxilliary handles shown below are present. These ensure the system remains secure.
3. Ensure the breaker handle is completely horizontal. The breaker handle does not need to be locked in its position, but it should be set this way to allow the transit case lid to be closed properly.
4. The encoder does not need to be removed for transport, but if it is then ensure it is stored in the designated location in the transit case foam.

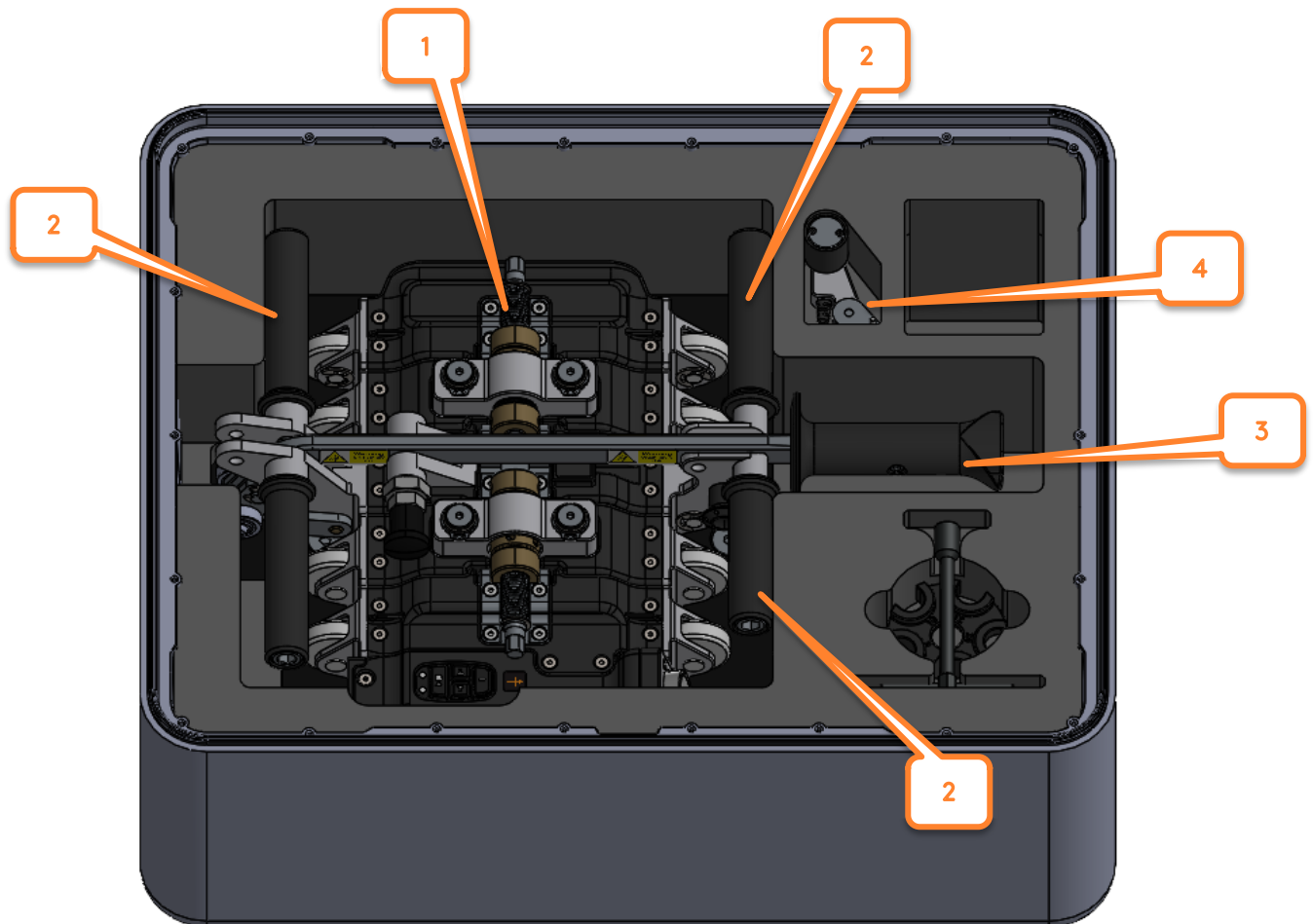

Figure 45 - System Shipping

## 12. Recommended Calibration / Reference Pipe Samples

### 12.1 General Recommendation

In order to perform a system check, it is recommended that reference pipes are obtained.

The reference pipe should ideally be of the same material, diameter and wall thickness of the component under inspection and include two main characteristics:

1. One or more known defect(s) of target diameter and depth so that alarm threshold and color palette can be set accordingly as mentioned in the setup section above, depending on the application and expected defects to be detected
2. One circumferential groove of a length that is longer than the head's coverage so that all sensors' can be checked at once with one pass over the groove. Recommended depth and width are 40% of wall thickness and 6 mm wide.

### 12.2 Specific Corrosion Types

The Pipescan HD system can detect any classification of defect consisting in volume loss of material in a ferro magnetic material provided a suitable signal response is possible. This means that specific reference samples can be created which can allow the user to inspect according to the inspection needs. The key in manufacturing a good reference sample is to include a defect (or series of defects) that are as close as possible in their geometry to the actual nature of the corrosion that is expected to be found.

The following image shows an example of calibration / reference pipe that can be used with Pipescan HD.

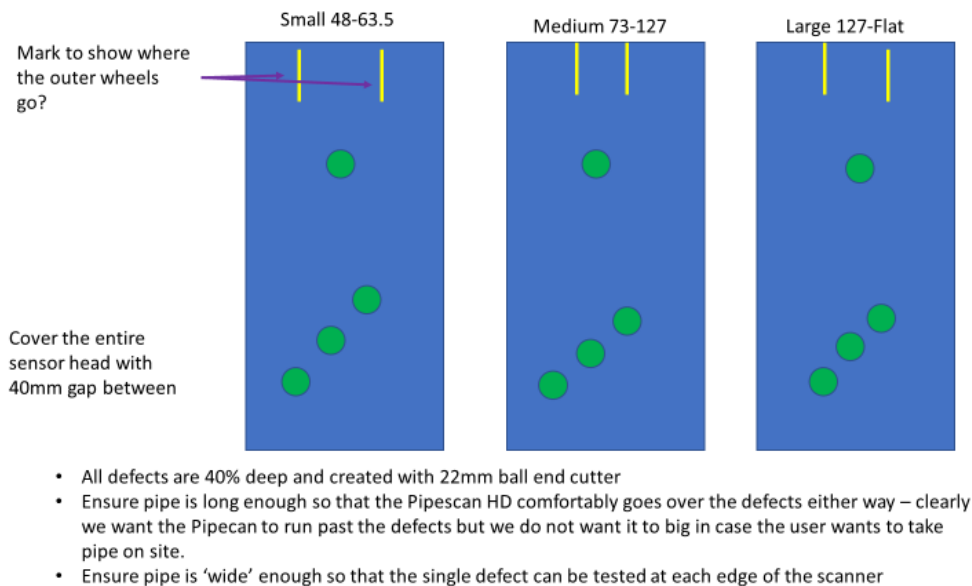

Figure 46 – Reference Pipe Examples



Chapter 5

# Maintenance

## 13. Maintenance

Before carrying out any probe maintenance, ensure all general precautions and safety precautions are understood and followed. Refer to Section 1 for details.

### 13.1 Magnetic Bridge Maintenance

- Magnets attract dirt.

When deemed necessary during inspection or after an inspection, clean the leading surface and magnet with a soft cloth. A vacuum cleaner is also an excellent option for removing ferrous material.

### 13.2 Wheel Replacement – 127XFLAT

For Pipescan HD 127xFlat Models manufactured post December 2021

To replace the wheels, follow the steps below:

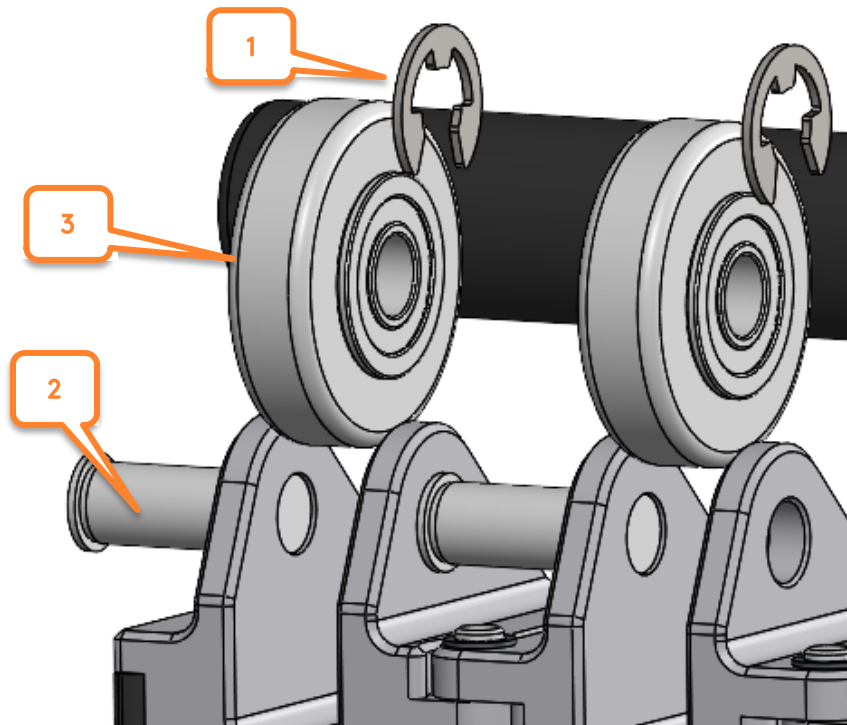

Figure 47 - Wheel Replacement

1. Using flathead screwdriver or similar tool, remove the E-Clips from the axle shaft.
2. Remove the axle shaft from the wheel bracket.  
**Note:** outer axle shafts must be removed first in order to access the inner axle shafts.
3. Remove the wheel.
4. Installation is the reverse of removal.

To replace the central bracket wheel, follow the steps below:

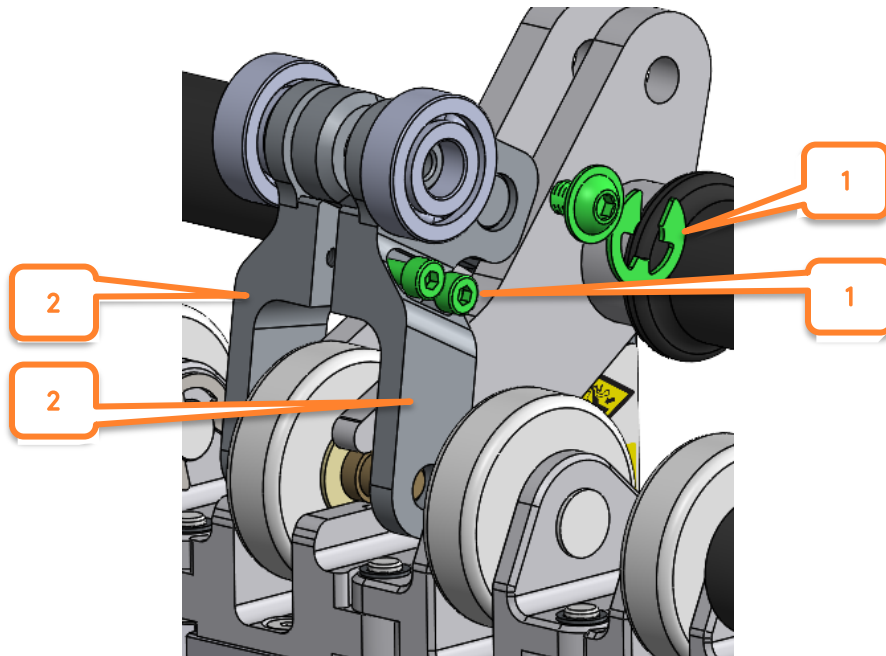

Figure 48 - Central Wheel Removal 1

1. Remove the flanged button screw and E-Clip highlighted in green and loosen the M4 bolts by 5-6 full turns using a 3mm Hex Key.
2. Separate the two halves of the handle jack bracket.

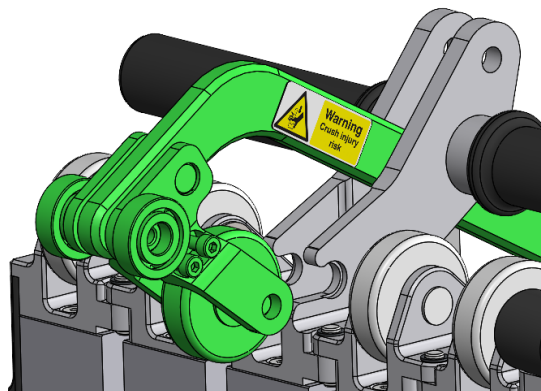

Figure 49 - Central Wheel Removal 2

3. Lower the breaker handle assembly out of the wheel bracket. The wheel and axle can now be removed in order to replace the wheel.
4. Installation is the reverse of removal. Ensure that during install, all fasteners are correctly installed and tightened with correct tools before use.

If spare parts are required, please contact [sales@eddyfi.com](mailto:sales@eddyfi.com)

Eddyfi UK Ltd  
Clos Llyn Cwm,  
Swansea Enterprise Park,  
Swansea,  
SA6 8QY,  
Wales, UK.  
+44 (0) 1792 798711

Eddyfi Technologies  
3425 Pierre-Ardouin Street,  
Québec (QC),  
G1P 0B3,  
Canada  
+1 418 780 1565

The information in this document is accurate as of its publication. Actual products may differ from those presented herein.  
© 2021 Eddyfi UK Ltd. Eddyfi Technologies, Eddyfi, Silverwing, Swift, Reddy, Pipescan and their associated logos are trademarks or registered trademarks of Eddyfi Technologies (wholly owned subsidiary of Eddyfi NDT, Inc.) in Canada and/or other countries. Eddyfi Technologies reserves the right to change product offerings and specifications without notice.

[www.eddyfi.com](http://www.eddyfi.com)

[info@eddyfi.com](mailto:info@eddyfi.com)

